

The F-Tool UniClamp reduces the consumption of electrode material

Simply saw the graphite, clamp it into the UniClamp, machine and erode.

All F-Tool UniClamp are from A like alignment to Z like Z-support identical. Electrodes can be removed from the UniClamp and re-clamped in reference position. The short clamping height reduces the consumption of electrode material.

Less set-up time, less consumption of electrode material, less costs

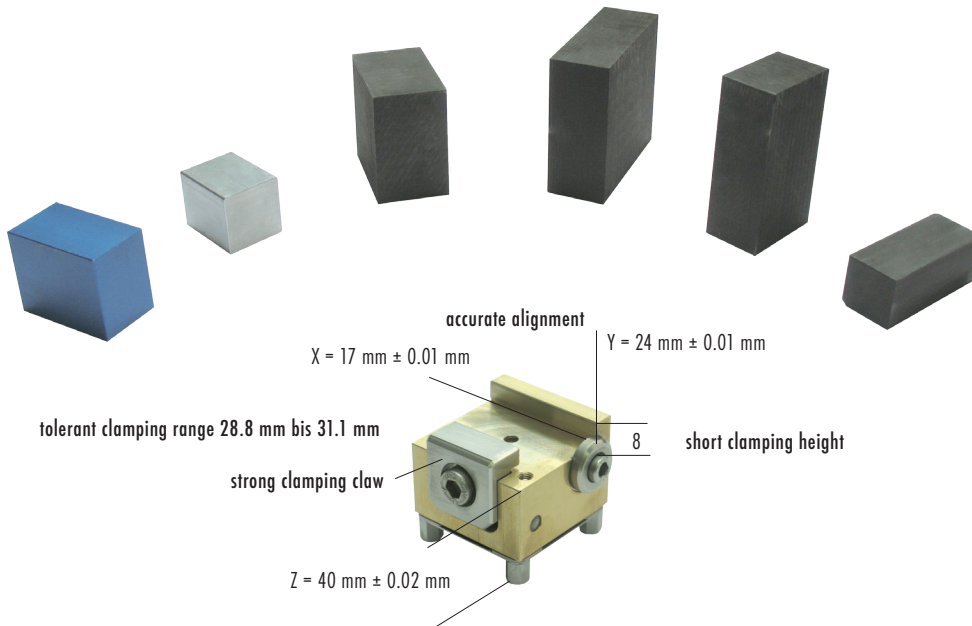

F-Tool UniClamp

The F-Tool UniClamp are new, basically developed as electrode holders. The strong clamping claw pushes the electrode to the reference surface and holds it firmly in position. Electrode blanks can simply be sawed off and clamped quickly. Also completed electrodes can be clamped permanently on different UniClamp in reference position. The F-Tool UniClamp is suited as well for clamping and machining of precision parts.

Article no.	Article	Quantity	Weight	Code
FT 01953	FTool UniClamp ER-30	1 piece	0.72 kg	A
FT 01957	FTool UniClamp ER-30 (Set of 10 pieces)	Set of 10 pieces	6.84 kg	A

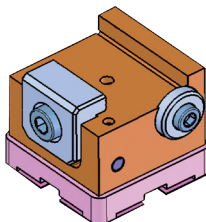

F-Tool UniClamp TR30 (compatible with 3R)

The F-Tool UniClamp are new, basically developed as electrode holders. The strong clamping claw pushes the electrode to the reference surface and holds it firmly in position. Electrode blanks can simply be sawed off and clamped quickly. Also completed electrodes can be clamped permanently on different UniClamp in reference position. The F-Tool UniClamp is suited as well for clamping and machining of precision parts.

Article no.	Article	Quantity	Weight	Code
FT 01954	FTool UniClamp TR-30	1 piece		A
FT 01958	FTool UniClamp TR-30 (Set of 10 pieces)	Set of 10 pieces		A